



Manufacturer

VEM motors GmbH - Werk Zwickau
Äußere Dresdner Str. 35

Customer

akkerstraat 10

08066 ZWICKAU
Deutschland

**Three-phase motors with squirrel cage rotor,
Housing grey cast iron**

Type		IE3-W41R 100 LY2
Design output	(kW)	3
Design torque	(Nm)	9,81
Class IE	[-]	IE3-87,1%
Efficiency determination		EN 60034-2-1
Duty type		S1
Design frequency	(Hz)	50
Design speed	[rpm]	2920
Voltage	(V)	230/400
Connection	[-]	D/Y
Current	[A]	10.43/6.00
Relative pull-in current	[-]	7,7
Relative starting torque	[-]	2,3
Relative pull-up torque	[-]	2,2
Relative pull-out torque	[-]	3,5
Efficiency100/75/50 %	[%]	87,1 / 88,6 / 87,6
Power factor	[-]	0,82
Th. cl.		155(F/B)
Coolant temperature	(°C)	-20...+40
Altitude above sea level	(m)	1000
Degree of protection IP		IP55
Moment of inertia	(kgm ²)	0,0045
Motor weight	(kg)	31
Bearing, D-side		6206 2Z C3
Bearing, N-side		6206 2Z C3
Grease type		Asonic GLY 32
A-sound pressure level	(dB)	a.A.

Options

Type of mounting	IMB34
Flange	FT 130[C 160]
Terminal box	Standard
Position of terminal box	on the top
Cable gland	Sealing plug
Position of cable entry	right
Shaft	Standard, 1 shaft end
Bearing	Easy bearing arrangement
Limit values to vibration velocity	Class A
	Balancing with half key
Colour system	01 Moderate (KK C2),RAL 7031 blue-grey
Delivery conditions and/or official regulations:	IEC / EN 60034-1

This document was produced electronically, all specifications are valid only after confirmation of the manufacturer

Data sheet

22.05.2024 MADE WITH VEM EKAT 2024



Three-phase motors with squirrel cage rotor,
Housing grey cast iron

IE3-W41R 100 LY2

Mounting position

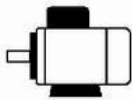

Type of mounting: IMB34
Flange: FT 130[C 160]
Position of terminal box: on the top
Brake type:
Forced-ventilation:

Terminal box: KA 05
Cable gland O: 1 xSealing plug

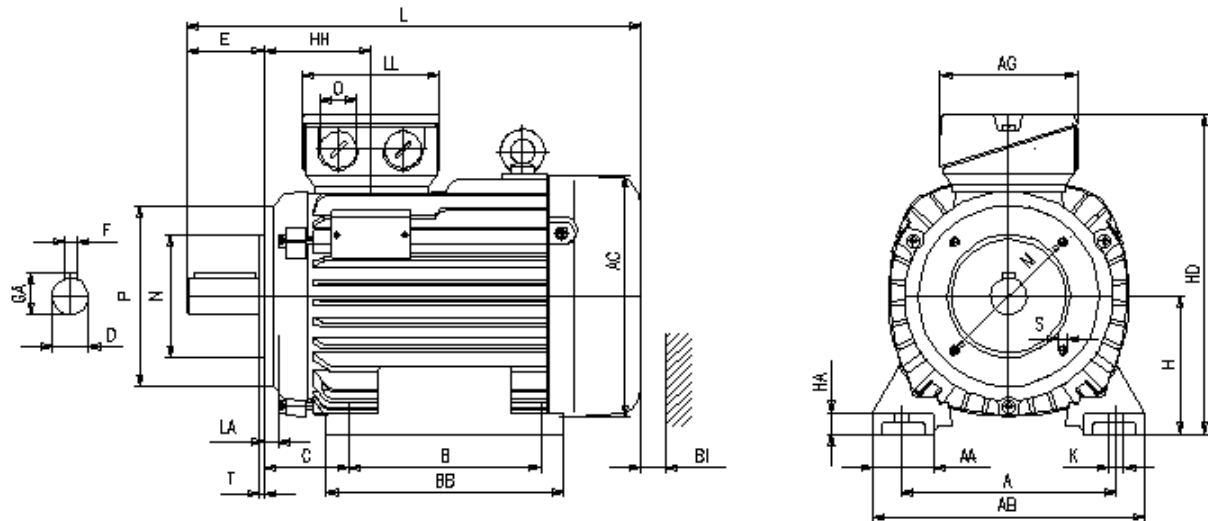

Motor

A	AA	AB	AC	AD	B	B'	BA	BA'	BB	C	CA	K	K'
160	42	193	196	-	140	-	-	-	175	63	-	12	12
L	LC	H	HA	HD	HH	BI	Protection cover			AG	LL	Terminal box	
357	-	100	13	236	77	20	L	-	92	92	92	BE	AH
												-	-

Flange

P	N	LA	M	T	S	Tolerances			
160	110	10	130	3,5	M8	H	N	D	DA
						-0,5	j6	k6	k6

Shaft-DS

D	E	GA	F	DB
28	60	31	8	DIN 332 DS- M10

Shaft-NS

DA	EA	GC	FA
-	-	-	-

DB...Centre hole

Delivery conditions and/or official regulations: IEC / EN 60034-1

This document was produced electronically, all specifications are valid only after confirmation of the manufacturer