



Manufacturer

Customer

VEM motors GmbH - Werk Wernigerode
Carl-Friedrich-Gauß-Straße 1

38855 WERNIGERODE
Deutschland

Three-phase motors with squirrel cage rotor,
Housing grey cast iron

Type	IE3-W43R 225 S4 TPM HW		
Design output	(kW)	37	
Design torque	(Nm)	240	
Class IE	[-]	IE3-93,9%	
Efficiency determination	EN 60034-2-1		
Duty type		S1	
Design frequency	(Hz)	50	
Design speed	[rpm]	1475	
Voltage	(V)	400/690	
Connection	[-]	D	Y
Current	[A]	67.0	38.8
Relative pull-in current	[-]	6,4	
Relative starting torque	[-]	2,2	
Relative pull-up torque	[-]	1,7	
Relative pull-out torque	[-]	2,6	
Efficiency100/75/50 %	[%]	93,9 / 94,4 / 94,2	
Power factor	[-]	0,85	
Th. cl.		155(F/B)	
Coolant temperature	(°C)	-20°C...+40°C	
Altitude above sea level	(m)	1000m	
Degree of protection IP		IP55	
Moment of inertia	(kgm ²)	0,356	
Motor weight	(kg)	341	
Bearing, D-side		6313 C3	
Bearing, N-side		6312 C3	
Relubrication interval	(h)		
Grease type		ASONIC GHY 72	
Grease amount	[cm ³]		
A-sound pressure level	(dB)	65	

Options

Type of mounting	IM B3
Flange	-
Terminal box	Standard
Position of terminal box	on the top
Cable gland	Sealing plug
Position of cable entry	right
Shaft	Standard, 1 shaft end
Bearing	Easy bearing arrangement
Special details to bearings	Fixed bearing, N-side
Winding protection	1 set ptc resistors
Limit values to vibration velocity	Class A
Colour system	Balancing with half key
Delivery conditions and/or official regulations:	01 Moderate (KK C2),RAL 7031 blue-grey IEC / EN 60034-1

This document was produced electronically, all specifications are valid only after confirmation of the manufacturer

Three-phase motors with squirrel cage rotor,
Housing grey cast iron

IE3-W43R 225 S4 TPM HW

Mounting position

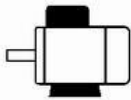

Type of mounting: IM B3
Flange: -
Position of terminal box: on the top
Brake type:
Forced-ventilation:

Terminal box: KK 100 A
Cable gland O: 1 xSealing plug

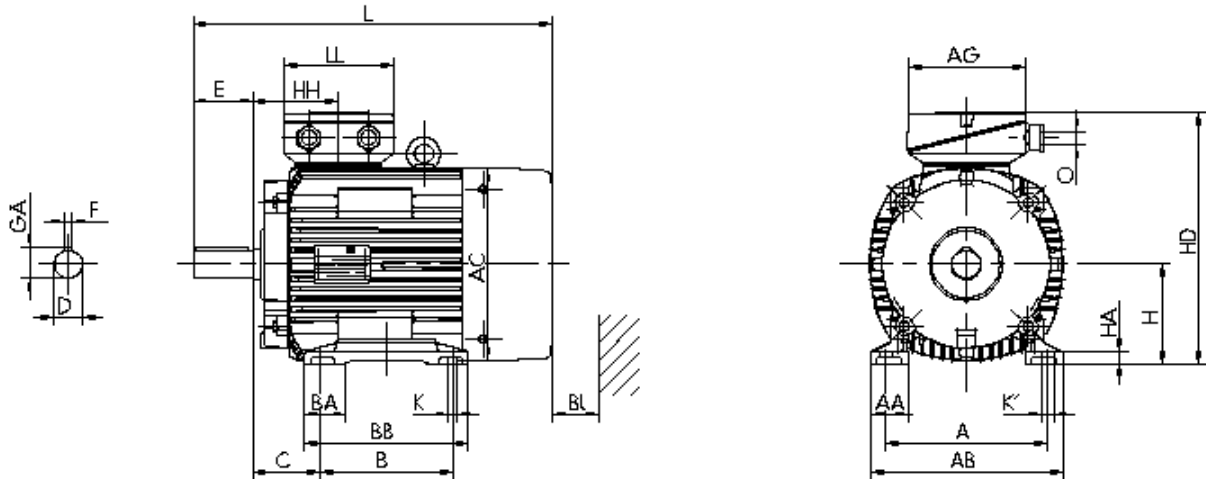

Motor

A	AA	AB	AC	AD	B	B'	BA	BA'	BB	C	CA	K	K'		
356	75	413	390	-	286		75	-	343	149	-	19	25		
												Protection cover		Terminal box	
L	LC	H	HA	HD	HH	BI	L	AG	LL	BE	AH				
847	-	225	25	527	168	90	-	213	207	-	-				

Flange

P	N	LA	M	T	S								
-	-	-	-	-	-								

Tolerances

H	N	D	DA
-0,5	h6	m6	m6

Shaft-DS

D	E	GA	F	DB
60	140	64	18	DIN 332 DS- M20

Shaft-NS

DA	EA	GC	FA
-	-	-	-

DB...Centre hole

Delivery conditions and/or official regulations: IEC / EN 60034-1

This document was produced electronically, all specifications are valid only after confirmation of the manufacturer