

Dimensional sheet



16.10.2015 MADE WITH VERSION: 7.80

Manufacturer

Customer

VEM motors GmbH
Carl-Friedrich-Gauß-Straße 1

38855 WERNIGERODE
Deutschland

Three-phase motor with squirrel cage rotor, brake motors
 brake type Stromag

B21R 315 MY4 SMG TPM HB NS LL IL WE HW

Mounting position

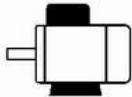

Type of mounting: IM B3
 Flange: -
 Position of terminal box: on the top
 Brake type: 4BZFM 160

Terminal box: KK 400 B
 Cable gland O: 1 xSealing plug

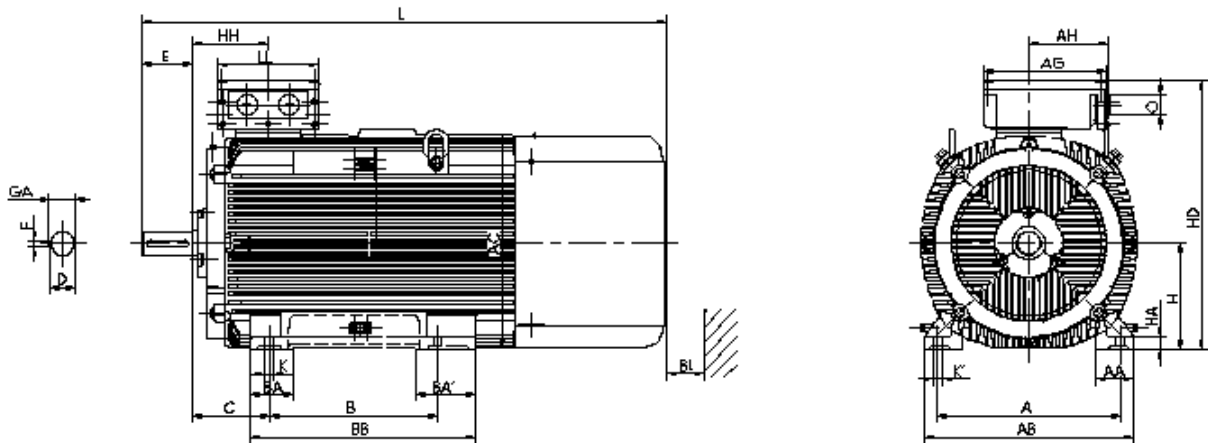

Motor

A	AA	AB	AC	AD	B	B'	BA	BA'	BB	C	CA	K	K'
508	110	590	610	-	457	-	120	-	573	216	-	28	35

Terminal box

L	LC	H	HA	HD	HH	BI	AG	LL	BE	AH
1660	-	315	44	809	230	55	415	340	-	265

Flange

P	N	LA	M	T	S	H	N	D	DA
-	-	-	-	-	-	-1	h6	m6	m6

Tolerances

Shaft-DS

D	E	GA	F	DB
90	170	95	25	DIN 332-DS M24

Shaft-NS

DA	EA	GC	FA
-	-	-	-

DB...Centre hole

Delivery conditions and/or official regulations: IEC / EN 60034-1

This document was produced electronically, all specifications are valid only after confirmation of the manufacturer